



WIX-SKD330 LCD NC 3D Shaker
Quick Reference Guide



Scan QR code for quick access to user manual or more information at
www.wixscientific.com.

Catalogue Number 10407001

The guide should be read before using the WIX-SKD330.

I. Unpacking

After unpacking, please check and verify the accessories in the packing box according to the instrument packing list.

II. Steps

1. Place the shaker in a stable and safe place.
2. Ensure the operating voltage specified on the shaker matches the grid supply voltage.
3. Install supporting clamps.

Loosen mounting screws of clamps (four in total).

Place the clamps on the oscillating plate (insert clamps claws between mounting screws of clamps and the oscillating plate).

Tighten mounting screws of clamps immediately.

4. Power on.
5. Turn on the power switch of the shaker.
6. Speed setting: rotate speed button to set oscillation speed (clockwise for increase, counterclockwise for decrease).
7. Time setting: rotate timer button to set oscillation time (clockwise for increase, counterclockwise for decrease. Decrease to display "-- : --" means time is infinite).
8. Run shaker

Continuous running: press speed button to start continuous running at the set speed.

Timing running: press timer button and the shaker starts to run for the set time at the set speed.

During running continuously of the shaker, press the timer button for timing running.

9. Stop shaker

Continuous running: press the speed button to stop running.

Timing running: press the speed button or timer button to stop running.

10. Turn off the power switch.

Note: Speed and time can not be set when shaker's running.

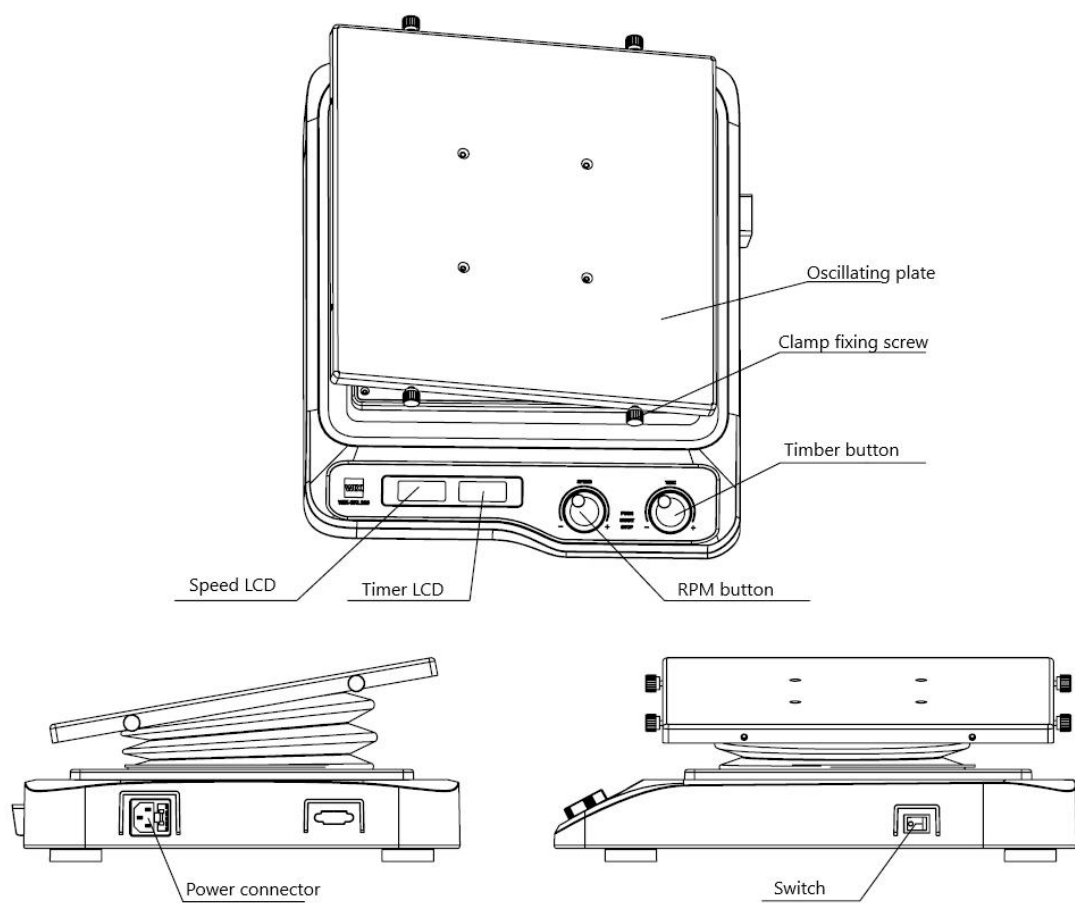

WIX-SKD330 structure diagram

Makes research and development simple



WIX TECHNOLOGY BEIJING CO., LTD

Tel: +86 010-89797600

E-mail: sales@wixscientific.com

Website: <http://www.wixscientific.com/>

Add: No. 8 Building DLTC Sci-Tech Park,

No.738 Changliu Road Machikou Town,

Changping District Beijing P.R.C.

Postcode: 102202